

PowerLogic power-monitoring units

ION7550RTU

Technical data sheet

2009



ION7550 RTU

Functions and characteristics



PowerLogic ION 7550RTU.

The PowerLogic ION7550RTU (remote terminal unit) is an intelligent web-enabled device ideal for combined utilities metering of water, air, gas, electricity and steam (WAGES). When combined with PowerLogic software, the ION7550RTU offers a seamless, end-to-end WAGES metering solution. Featuring a large, high-visibility display and overall versatility of the PowerLogic system, the ION7550RTU provides extensive analog and digital I/O choices and is a cost-effective dedicated WAGES solution when compared to a traditional meter. The device automatically collects, scales and logs readings from a large number of connected meters or transducers and delivers information to one or more head-end systems through a unique combination of integrated Ethernet, modem or serial gateways. As part of a complete enterprise energy management solution, the ION7550RTU can be integrated with PowerLogic ION Enterprise software, or other SCADA, information and automation systems.

Applications

- WAGES metering.
- Data concentration through multi-port, multi-protocol communications.
- Equipment status monitoring and control.
- Programmable setpoints for out-of-limit triggers or alarm conditions.
- Integrated utility metering with advanced programmable math functions.

Main characteristics

Increase efficiency

Reduce waste and optimise equipment operation to increase efficiency.

Easy to operate

Screen-based menu system to configure meter settings. Bright LCD display with adjustable contrast.

Integrate with software

Easily integrated with PowerLogic or other energy management enterprises, including SCADA systems.

Transducer and equipment condition monitoring

Versatile communications, extensive I/O points, clock synchronization, event logging and sequence of events recording capabilities for transducer and equipment condition and status monitoring at utility substations.

Set automatic alarms

Alarm setpoint learning feature for optimum threshold settings.

Up to 10 Mbytes of memory

For archiving of data and waveforms.

Notify alarms via email

High-priority alarms sent directly to the user's PC. Instant notification of power quality events by email.

Part numbers

ION7550RTU	
ION7550	M7550

See page 6 for order code explanations.

ION7550 RTU

Functions and characteristics (cont.)

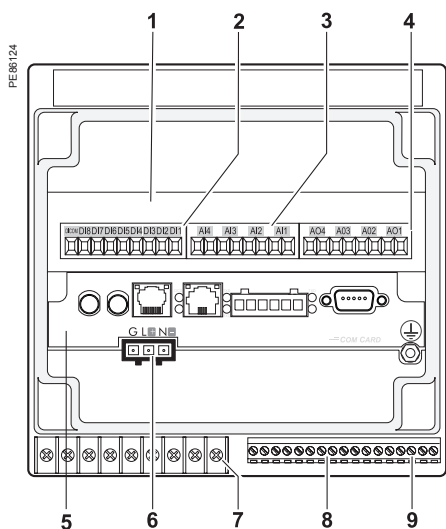

PowerLogic® ION7550RTU.

- 1 I/O expansion card.
- 2 Digital inputs.
- 3 Analog inputs.
- 4 Analog outputs.
- 5 Communications card.
- 6 Power supply.
- 7 Form C digital outputs.
- 8 Digital inputs.
- 9 Form A digital outputs.

Selection guide	ION7550RTU
Data recording	
Min/max of instantaneous values	■
Data logs	■
Event logs	■
Trending/forecasting	■
SER (Sequence of event recording)	■
Time stamping	■
GPS synchronisation (1 ms)	■
Memory (in Mbytes)	10
Display and I/O	
Front panel display	■
Pulse output	1
Digital or analogue inputs(max)	24
Digital or analogue outputs (max, including pulse output)	30
Communication	
RS 485 port	1
RS 485 / RS 232 port	1
Optical port	1
Modbus protocol	■
Ethernet port (Modbus/TCP/IP protocol)	1
Ethernet gateway (EtherGate)	1
Alarms (optional automatic alarm setting)	■
Alarm notification via email (Meterm@il)	■
HTML web page server (WebMeter)	■
Internal modem	1
Modem gateway (ModemGate)	■
DNP 3.0 through serial, modem, and I/R ports	■

ION7550 RTU

Functions and characteristics (cont.)

PE6017



PowerLogic ION7550RTU.

Electrical characteristics		
Data update rate		1/2 cycle or 1 second
Power supply	AC	85-240 V AC $\pm 10\%$ (47-63 Hz)
	DC	110-300 V DC $\pm 10\%$
	DC low voltage (optional)	20-60 V DC $\pm 10\%$
	Ride-through time	100 ms (6 cycles at 60 Hz) min. at 120 V DC
	Burden	Standard: typical 15 VA, max 35 VA Low voltage DC: typical 12 VA, max 18 VA
Input/outputs ⁽¹⁾	Standard	8 digital inputs (120 V DC) 3 relay outputs (250 V AC / 30 V DC) 4 digital outputs (solid state)
	Optional	8 additional digital inputs 4 analog outputs, and/or 4 analog inputs
Mechanical characteristics		
Weight		1.9 kg
IP degree of protection (IEC 60529)		IP52
Dimensions	Standard model	192 x 192 x 159 mm
	TRAN model	235.5 x 216.3 x 133.1 mm
Environmental conditions		
Operating temperature	Standard power supply	-20 to +70°C
	Low voltage DC supply	-20 to +50°C
	Display operating range	-20 to +70°C
Storage temperature	Display, TRAN	-40 to +85°C
Humidity rating		5 to 95% non-condensing
Installation category		III (2000m above sea level)
Dielectric withstand		As per EN 61010-1, IEC 62051-22A ⁽²⁾
Electromagnetic compatibility		
Electrostatic discharge		IEC 61000-4-2
Immunity to radiated fields		IEC 61000-4-3
Immunity to fast transients		IEC 61000-4-4
Immunity to surges		IEC 61000-4-5
Conducted and radiated emissions		CISPR 22
Safety		
Europe		IEC 61010-1

(1) Consult the ION7550 / ION7650 installation guide for complete specifications.
 (2) IEC 62051-22B with serial ports only.

ION7550 RTU

Functions and characteristics (cont.)

Communication	
RS 232/485 port ⁽¹⁾	Up to 115,200 bauds (57,600 bauds for RS 485), ION, DNP 3.0, Modbus, GPS, EtherGate, ModemGate, Modbus Master
RS 485 port ⁽¹⁾	Up to 115,200 bauds, ION, DNP 3.0, Modbus, GPS, EtherGate, ModemGate, Modbus Master
Infrared port ⁽¹⁾	ANSI type 2, up to 19,200 bauds, ION, Modbus, DNP 3.0
Ethernet port	10BaseT, 100BaseTX. RJ45 connector, 10/100 m link
Fibre-optic Ethernet link	100Base FX, SC duplex connector, 1300 nm, FO multimode with gradient index 62.5/125 µm or 50/125 µm, 2000 m link
Protocol	ION, Modbus, TCP/IP, DNP 3.0, Telnet
EtherGate	Communicates directly with up to 62 slave devices via available serial ports
ModemGate	Communicates directly with up to 31 slave devices
WebMeter	5 customisable pages, new page creation capabilities, HTML/XML compatible
Firmware characteristics	
High-speed data recording	Down to 5ms interval burst recording, stores detailed characteristics of disturbances or outages. Trigger recording by a user-defined setpoint, or from external equipment.
Load profiling	Channel assignments (800 channels via 50 data recorders) are configurable for any measurable parameter. Trigger recorders based on time interval, calendar schedule, alarm/event condition, or manually.
Trend curves	Access historical data at the front panel. Display, trend and continuously update historical data with date and timestamps for up to four parameters simultaneously.
Alarms	Threshold alarms: adjustable pickup and dropout setpoints and time delays, numerous activation levels possible for a given type of alarm user-defined priority levels boolean combination of alarms is possible using the operators NAND, OR, NOR and XOR
Advanced security	Up to 16 users with unique access rights. Perform resets, time syncs, or meter configurations based on user privileges
Memory	5 to 10 Mbytes (specified at time of order)
Firmware update	Update via the communication ports
Display characteristics	
Integrated display	Back lit LCD, configurable screens
Languages	English

⁽¹⁾ All the communication ports may be used simultaneously.

ION7550 RTU

Functions and characteristics (cont.)



Sample ION7550RTU part number.

Part numbers

Item	Code	Description
1 Model	7550	ION7550 device
2 Form Factor	A0	Integrated display with front optical port, 5 MB logging memory, and 512 samples/cycle resolution.
	B0	Integrated display with front optical port, 10 MB logging memory, and 512 samples/cycle resolution.
	T0	Transducer (no display) version, with 5 MB logging memory.
	U0	Transducer (no display) version, with 10 MB logging memory.
3 RTU option	N9	RTU option
4 Power Supply	B	Standard power supply (85-240 VAC, ±10%/47-63 Hz / 110-330 VDC, ±10%)
	C	Low voltage DC power supply (20-60 VDC)
5 Internal use	9	This field for internal use only
6 Communications	A0	Standard communications (1 RS-232/RS-485 port, 1 RS-485 port). Integrated display models also include 1 ANSI Type 2 optical communications port.
	C1	Standard communications plus 10BASE-T/100BASE-TX Ethernet (RJ-45), 56k universal internal modem (RJ-11). Ethernet, modem gateway functions each use a serial port.
	D7	Standard comms plus 10BASE-T/100BASE-TX Ethernet (RJ-45) and 100BASE-FX Ethernet Fiber, 56k universal internal modem (RJ-11). Ethernet and modem gateway functions each use a serial communications port.
	E0	Standard communications plus 10BASE-T/100BASE-TX Ethernet (RJ-45). Ethernet gateway function uses serial port.
	F1	Standard communications plus 10BASE-T/100BASE-TX Ethernet (RJ-45) and 100BASE-FX (SC fiber optic connection). Ethernet gateway uses a serial port.
	M1	Standard communications plus 56k universal internal modem (RJ-11). Modem gateway uses serial communications port.
7 I/O	A	Standard I/O (8 digital inputs, 3 Form C relays, 4 Form A solid-state outputs)
	D	Standard I/O plus Expansion I/O card (8 additional digital inputs & four 0 to 1 mA analog inputs)
	E	Standard I/O plus Expansion I/O card (8 additional digital inputs & four 0 to 20 mA analog inputs)
	H	Standard I/O plus Expansion I/O card (8 additional digital inputs & four -1 to 1 mA analog outputs)
	K	Standard I/O plus Expansion I/O card (8 additional digital inputs & four 0 to 20 mA analog outputs)
	N	Standard I/O plus Expansion I/O card (8 additional digital inputs & four 0 to 20 mA analog inputs and four 0 to 20 mA outputs)
	P	Standard I/O plus Expansion I/O card (8 additional digital inputs & four 0 to 1 analog inputs and four -1 to 1 mA analog outputs)
8 Security	0	Password protected, no hardware lock
9 Special Order	A	None
	C	Tropicalisation treatment applied

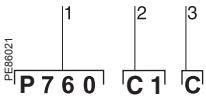

Example order code. Use this group of codes when ordering the PowerLogic ION7550RTU communication or I/O card.

- 1 Communications or I/O card.
- 2 Type.
- 3 Special order.

Communications Card			
Item	Code	Description	
1	Comm card	P765C ION7550RTU communication card for field retrofit installations	
2	Type	A0	Standard communications (1 RS-232/RS-485 port, 1 RS-485 port). Front optical port support for meters with integrated display.
		C1	Standard communications plus 10BASE-T/100BASE-TX Ethernet (RJ-45), 56k universal internal modem (RJ-11; the modem port is shared with the front optical port). Ethernet and modem gateway functions each use a serial communications port.
		D7	Standard communications plus 10BASE-T/100BASE-TX Ethernet, 100BASE-FX Ethernet Fiber, 56k universal internal modem (RJ-11; the modem port is shared with the front optical port). Ethernet and modem gateway functions each use a serial communications port.
		E0	Standard communications plus 10BASE-T/100BASE-TX Ethernet. Ethernet gateway function uses a serial communications port.
		F1	Standard communications plus 10BASE-T/100BASE-TX Ethernet, 100BASE-FX Ethernet Fiber (SC fiber optic connection). Ethernet gateway function uses a serial communications port.
		M1	Standard communications plus 56k universal internal modem (RJ-11; the modem port is shared with the front optical port). Modem gateway function uses a serial communications port.
		3	Special order
C	Tropicalization treatment applied		

ION7550 RTU

Functions and characteristics (cont.)

Part numbers (cont'd)

Input/Output expansion card

Item	Code	Description
I/O card	P760A	Expansion I/O for field retrofit installations.
Type	D	Expansion I/O card with eight digital inputs, four 0 to 1 mA analog inputs
	E	Expansion I/O card with eight digital inputs, four 0 to 20 mA analog inputs
	H	Expansion I/O card with eight digital inputs, four -1 to 1 mA analog outputs
	K	Expansion I/O card with eight digital inputs, four 0 to 20 mA analog outputs
	N	Expansion I/O card with eight digital inputs, four 0 to 20 mA analog inputs & four 0 to 20 mA outputs
	P	Expansion I/O card with eight digital inputs, four 0 to 1 analog inputs and four -1 to 1 mA analog outputs
Special Order	A	None
	C	Tropicalization treatment applied

OpenDAC rack, controllers, power supply

70LRCK16-48	OpenDAC rack. Holds up to 8 OpenLine modules to provide up to 16 I/O points. Requires communications controller
72-MOD-4000	OpenDAC OpenDAC RS-485 serial module. Communications controller for use in a Modbus RTU network. Supports up to 2 70LRCK16-48 OpenDAC racks
72-ETH-T000	OpenDAC Ethernet network module for use on an Modbus/TCP Ethernet network. Supports up to 2 OpenDAC racks
PS-240-15W	85-264VAC/110-370VDC 15 Watt power supply. Required for applying power to the racks and controllers

OpenLine digital I/O modules

70L-IAC	digital input, 120VAC
70L-IACA	digital input, 220VAC
70L-IDC	digital input, 3-32VDC
70L-IDCB	digital input, fast switching
70L-IDCNP	digital input, 15-32VAC/10-32VDC
70L-IDC5S	dry contact closure-sensing DC input
70L-ISW	input test module
70L-OAC	digital output, 120VAC
70L-OACL	digital output, 120VAC inductive loads
70L-OACA	digital output, 220VAC
70L-OACAL	digital output, 220VAC inductive loads
70L-ODC	digital output, 3-60VDC fast
70L-ODCA	digital output, 4-200 VDC
70L-ODCB	digital output, fast switching
70L-ODC5R	digital output, dry contact

OpenLine analog I/O modules

73L-II020	analog input, current, 0-20mA
73L-II420	analog input, current, 4-20mA
73L-ITCJ	analog input, temperature, J-type TC
73L-ITCK	analog input, temperature, K-type TC
73L-ITCT	analog input, temperature, T-type TC
73L-ITR100	analog input, temperature, RTD
73L-ITR3100	analog input, temperature, 3wire RTD
73L-ITR4100	analog input, temperature, 4wire RTD
73L-IV1	analog input, voltage, 0-1VDC
73L-IV10	analog input, voltage, 0-10VDC
73L-IV10B	analog input, voltage, -10 to 10VDC
73L-IV100M	analog input, voltage, 0-100VDC
73L-IV5	analog input, voltage, 0-5VDC
73L-IV5B	analog input, voltage, -5 to 5VDC
73L-IV50M	analog input, voltage, 0-50mV
73L-OI020	analog output, current, 0-20mA
73L-OI420	analog output, current, 4-20mA
73L-OV10	analog output, voltage, 0-10VDC
73L-OV10B	analog output, voltage, -10 to 10VDC
73L-OV5	analog output, voltage, 0-5VDC
73L-OV5B	analog output, voltage, -5 to 5VDC

ION7550 RTU

Installation and connection

ION7550RTU dimensions

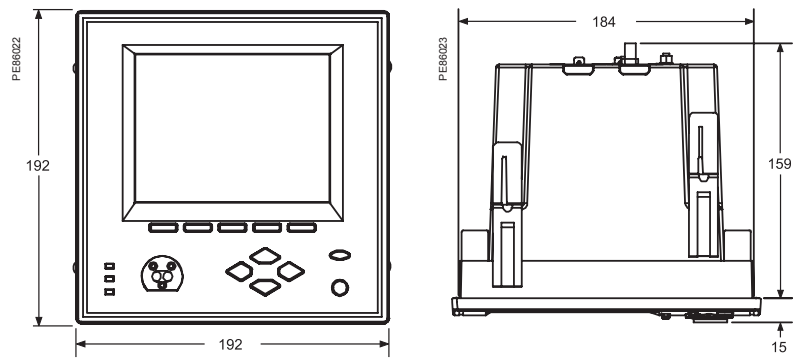

Front-panel mounting

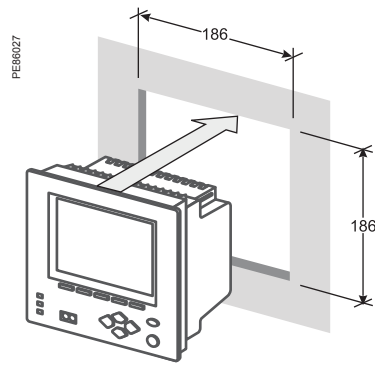

Power supply

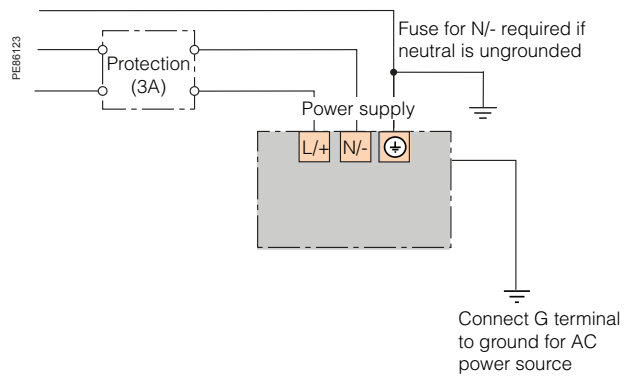

Note: the current and voltage terminal strip (I52, I51, I42, I41, I32, I31, I22, I21, I12, I11, V4, V3, V2, V1, Vref) is not present on the RTU.

ION7550 RTU

Installation and connection (cont.)

Form C digital outputs: mechanical relays R1 - R3

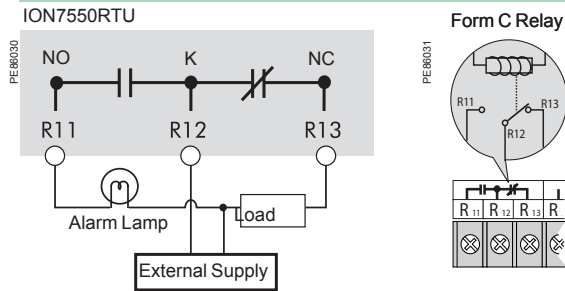

Note: Mechanical relays should always be protected by external fuses

Form A digital outputs: solid state relays D1 - D4

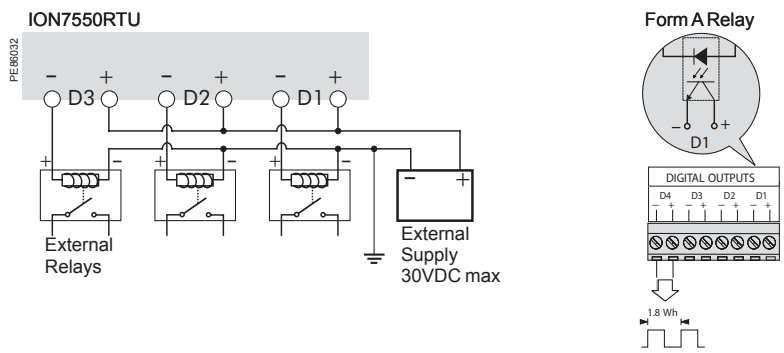

Note: D4 output is factory-configured to pulse once every 1.8 Wh for Class 20 meters, or once every 0.18Wh for Class 2 meters (for calibration testing purposes).

Digital inputs: S1 - S8

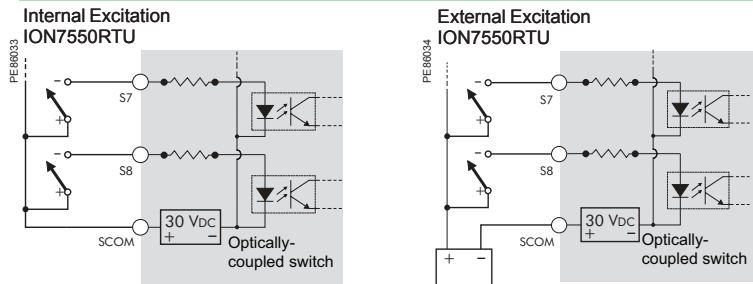

Note: External Supply = 130 VDC max

Digital inputs: DI1 - DI8 (option)

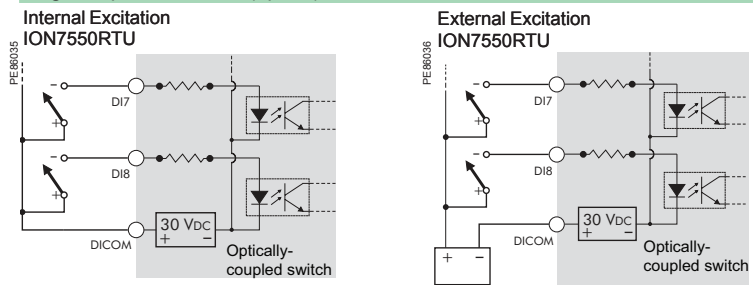

Note: External Supply = 50 VDC max

ION7550 RTU

Installation and connection (cont.)

Analog inputs: AI1 to AI4 (option)

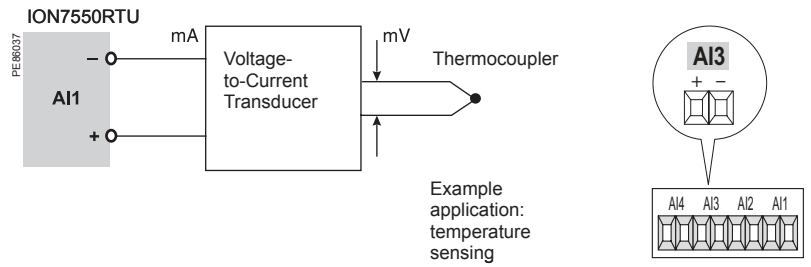

Note: do not connect the analog inputs of the I/O card to the analog outputs on the same I/O card.

Analog outputs: AO1 to AO4 (option)

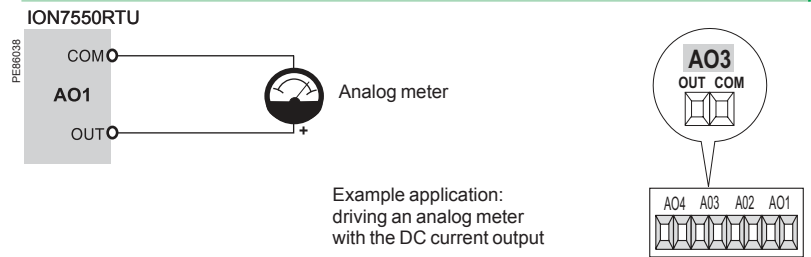

Note: do not connect the analog inputs of the I/O card to the analog outputs on the same I/O card.

Schneider Electric Industries SAS

35 Rue Joseph Monier
CS 30323
92506 Rueil Malmaison Cedex
Tel : +33 (0)1 41 29 70 00

www.schneider-electric.com www.powerlogic.com

AMTED307012EN ART#831050
© 2008 - Schneider Electric - All rights reserved 01-2009

As standards, specifications and designs develop from time to time, always ask for confirmation of the information given in this publication. PowerLogic, ION, ION Enterprise, MeterM@il and Modbus are either trademarks or registered trademarks of Schneider Electric.



Printed on recycled paper.

Design: Schneider Electric
Photos: Schneider Electric
Printed: Imprimerie du Pont de Claix - made in France