

PowerLogic power-monitoring units

Power Meter Series PM9

Technical data sheet

2006





Power Meter Series PM9.

The PowerLogic® Power Meter Series PM9 offers the basic measurement capabilities required to monitor an electrical installation in a 4-module case (18 mm modules).

They can be used to monitor 2-, 3- and 4-wire low-voltage systems and connect to external current transformers. With the large backlit display, you can monitor all three phases at the same time.

Three versions are available for one or two supply voltages (220 to 240 V AC or 24 to 48 V DC):

- PM9 for basic measurements
- PM9P for basic measurements with pulse output
- PM9C for basic measurements with Modbus RS485 output.

Applications

Panel instrumentation.
Sub-billing / cost allocation.
Remote monitoring of an electrical installation.

Characteristics

Only 72 mm wide (four 18 mm modules)
Compact design for optimised installation.

Large backlit display
Simultaneous monitoring of all three phases.

Demand power
Monitoring of subscribed-power overruns.

IEC 62053-21 Class 2 for energy
For sub-billing and cost-allocation applications.

Part numbers

Type	Voltage	Width in 9 mm modules	Part no.
Power Meter PM9	220 to 240 V AC	8	15199
Power Meter PM9P	220 to 240 V AC	8	15197
Power Meter PM9C	220 to 240 V AC	8	15198
Power Meter PM9	24 to 48 V DC	8	15274
Power Meter PM9P	24 to 48 V DC	8	15275
Power Meter PM9C	24 to 48 V DC	8	15276

Selection guide		PM9	PM9P	PM9C
General				
Use on LV systems only	1P + N, 3P, 3P + N	■	■	■
Current and voltage accuracy		0.5 %	0.5 %	0.5 %
Energy and power accuracy		2 %	2 %	2 %
Direct voltage connection		450 V	450 V	450 V
Instantaneous rms values				
Current	3 phases and neutral	■	■	■
Voltage	Phase-to-neutral and phase-to-phase	■	■	■
Frequency		■	■	■
Active and reactive power	Total and per phase	■	■	■
Apparent power	Total	■	■	■
Power factor	Total	■	■	■
Energy values				
Active energy		■	■	■
Reactive energy		■	■	■
Demand values				
Active, reactive, apparent power	Present and max. values	■	■	■
Other measurements				
Hour counter		■	■	■
Display and I/O				
Backlit LCD display		■	■	■
Pulse output		-	1	-
Communication				
RS485 port		-	-	■
Modbus protocol		-	-	■

Electrical characteristics		
Type of measurement		On single-phase (1P + N) or three-phase (3P, 3P + N) AC systems
Measurement accuracy	Current and voltage	0.5 % of reading
	Power	2 % of reading from pf 0.8 leading to 0.5 lagging
	Frequency	0.2 Hz
	Power factor	2 % from 0.8 leading to 0.5 lagging
	Active energy	Class 2 as defined by IEC 62053-21
	Reactive energy	Class 2 as defined by IEC 62053-23
Input-voltage characteristics	Measured voltage	50 to 450 V AC (direct) and up to 1000 V AC (with external VT)
	Permissible overload	1.15 Un
	Frequency measurement range	45 to 65 Hz
Input-current characteristics	CT ratings	Adjustable from 5 to 10000 A
	Secondary	5 A
	Metering over-range	15 mA to 6 A
	Permissible overload	6 A continuous 20 A 10 s 50 A 1 s
	Load	0.55 VA
	Input current	Not isolated
Control Power	AC	220 to 240 V AC ($\pm 10\%$), < 5 VA
	DC	24 to 48 V DC ($\pm 20\%$)
Pulse output (PM9P)		Static output, 350 V AC/DC max., 130 mA max. at 25 °C, derating 1 mA/°C above 25 °C, 5 kV insulation
Mechanical characteristics		
Weight		0.3 kg
IP degree of protection		IP52 (front display)
Dimensions		72 x 90 x 66 (mm)
Connection		Tunnel terminals, 1 x 4 mm ²
Environmental conditions		
Operating temperature		-5 °C to +55 °C
Pollution degree		2
Installation category		III for distribution systems up to 260/450 V
Electromagnetic compatibility	Electrostatic discharge	Level III (IEC 61000-4-2)
	Immunity to radiated fields	Level III (IEC 61000-4-3)
	Immunity to fast transients	Level IV (IEC 61000-4-4)
	Immunity to impulse waves	Level IV (IEC 61000-4-5)
	Conducted and radiated emissions	Class B (CISPR11)
Safety		
		CE
Communication		
RS485 port (PM9C) remote reading and reset		2-wire, 9600 or 19200 bauds, Modbus RTU, ELSV circuit, 6 kV impulse withstand (double insulation)

Dimensions

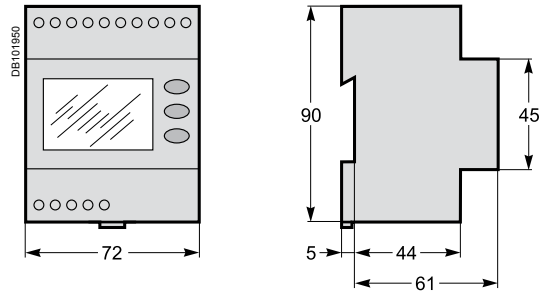

Power Meter Series PM9 Installation and connection (cont.)

PM9/4-wire connection with 3 CTs

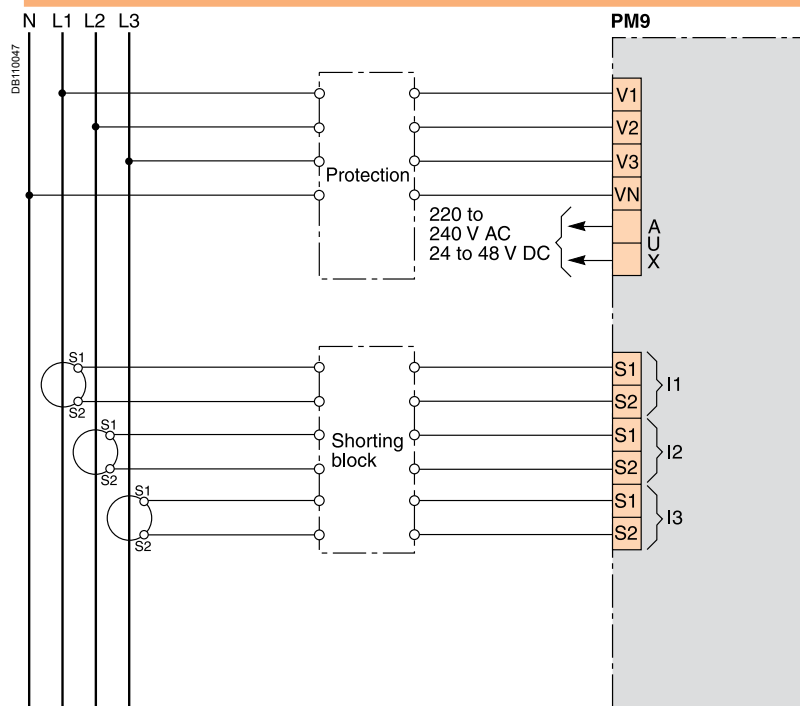

Connection example.

PM9P/4-wire connection with 3 CTs

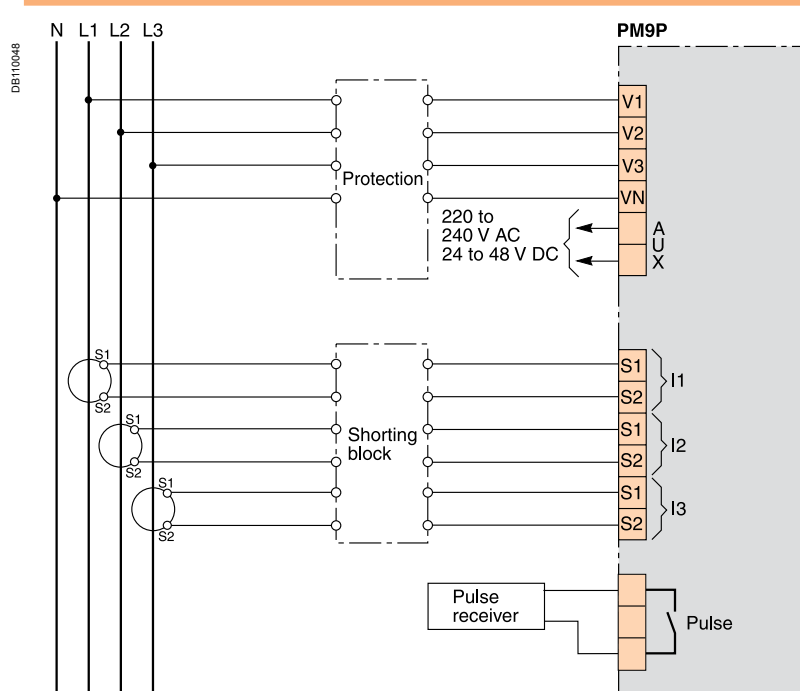

Connection example.

Note: other types of connection are possible. See product documentation.

PM9C/4-wire connection with 3 CTs

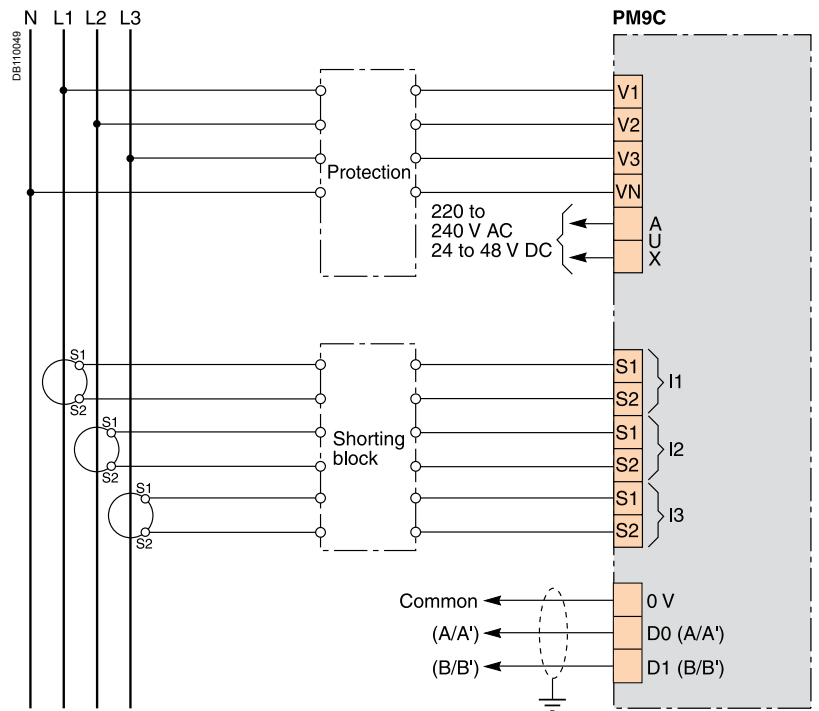

Connection example.

Note: other types of connection are possible. See product documentation.

Schneider Electric Industries SAS

Postal address:
Electrical Distribution Communication
38050 Grenoble cedex 9 - France
Tel : +33 (0)4 76 57 60 60

<http://www.schneider-electric.com>
<http://www.merlin-gerin.com>

As standards, specifications and designs change from time to time, please ask for confirmation of the information given in this publication.



*This document has been printed
on ecological paper.*

Design: Ameg
Publication: Schneider Electric
Printed: